

WCh-7 refrigerated counter



STANDARD FEATURES

- pivoting front glass
- gravitational cooling
- storage compartment
- thermostat with automatic defrost and digital display
- ABS sides and hull insulated with eco-friendly polyurethane foam
- handout shelf
- display lighting with a white fluorescent lamp
- night covers
- built-in refrigerating unit

OPTIONAL FEATURES

- working top made of granite or stainless sheet
- a movable separator
- a lower shelf for customer use
- fluorescent lamp for meat display
- cascade shelf

Cross section and measurements

Technical data

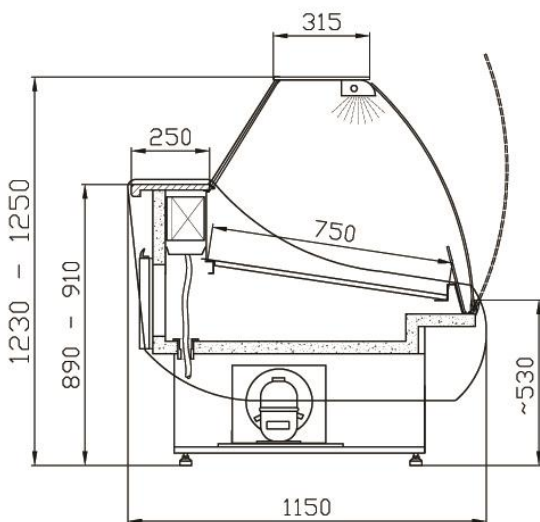

Length	mm	1330	1570	2000	2580	3060
Width	mm	1150				
Height	mm	1230 - 1250				
Temperature range	°C	from +1 to +7°C in the surround temperature 25°C and relative humidity 60%				
Refrigerating medium	-	R507				
Useful capacity	l	400	440	610	750	900
Display space	m ²	0,95	1,1	1,45	1,88	2,24
Nominal voltage	V	230/50Hz				
Nominal power	W	340	420	590	600	650
Power consumption	kWh/24 h	6,2	6,5	8,9	9,1	9,8
Power consumption per unit of length	W/m	450				
Weight	kg	140	175	215	270	320

The device serves for short-term storage and display of food previously cooled to its storage temperature

The colours displayed on the webpage may diverge from reality. Please use a colour scale to select your colour.

We reserve the right to introduce changes without notice.

The present catalogue card is not a trade offer according to the provisions of the Commercial Law.